

Classification of Laboratory Ventilation Design Levels

Developed by

ASHRAE Technical Committee 9.10, Laboratory Systems
Laboratory Classification Subcommittee

In partnership with

American Chemical Society
Division of Chemical Health and Safety
and

American Industrial Hygiene Association
Laboratory Health and Safety Committee



Atlanta

This publication was developed by the Laboratory Classification Subcommittee of ASHRAE Technical Committee (TC) 9.10, Laboratory Systems, with support from members of other organizations that specialize in laboratory health and safety.

ASHRAE TC 9.10 Laboratory Classification Subcommittee

Adam Bare, PE, Chair
Newcomb & Boyd, LLP

Roland Charneux, PE, HFDP, ASHRAE Fellow
Pageau & Morel

Jim Coogan
Siemens

Gary Goodson, PE
Exposure Control Technologies, Inc.

Henry Hays
USDA Agricultural Research Service

Nathan Ho, PE
P2S Engineering, Inc.

Guy Perreault
Evap-Tech MTC Inc.

Tom Smith
Exposure Control Technologies, Inc.

Contributors from Other Organizations

Debbie Decker
University of California, Davis

Ken Kretchman
North Carolina State University

Rebecca Lally, CIH
Southern California Edison

Elizabeth Kolacki, PE
Cornell University

Peter Slinn
Natural Resources Canada

Ralph Stuart, CIH
Keene State College

Ellen Sweet
Cornell University

This work is the product of an effort started by Andrew Dymek well over 10 years ago.

Thanks to everyone involved for their help in producing this document.

Special thanks go to Tom Smith for his considerable efforts.

Updates/errata for this publication
will be posted on the ASHRAE website at
www.ashrae.org/publicationupdates.

ISBN 978-1-939200-90-7 (PDF)

© 2018 ASHRAE
1791 Tullie Circle, NE
Atlanta, GA 30329
www.ashrae.org

All rights reserved.

ASHRAE is a registered trademark in the U.S. Patent and Trademark Office, owned by the American Society of Heating, Refrigerating and Air-Conditioning Engineers, Inc.

ASHRAE has compiled this publication with care, but ASHRAE has not investigated, and ASHRAE expressly disclaims any duty to investigate, any product, service, process, procedure, design, or the like that may be described herein. The appearance of any technical data or editorial material in this publication does not constitute endorsement, warranty, or guaranty by ASHRAE of any product, service, process, procedure, design, or the like. ASHRAE does not warrant that the information in the publication is free of errors, and ASHRAE does not necessarily agree with any statement or opinion in this publication. The entire risk of the use of any information in this publication is assumed by the user.

No part of this publication may be reproduced without permission in writing from ASHRAE, except by a reviewer who may quote brief passages or reproduce illustrations in a review with appropriate credit, nor may any part of this publication be reproduced, stored in a retrieval system, or transmitted in any way or by any means—electronic, photocopying, recording, or other—without permission in writing from ASHRAE. Requests for permission should be submitted at www.ashrae.org/permissions.

Library of Congress Cataloging in Publication Control Number: 2018011558

ASHRAE STAFF	SPECIAL PUBLICATIONS	Mark S. Owen , <i>Editor/Group Manager of Handbook and Special Publications</i>
		Cindy Sheffield Michaels , <i>Managing Editor</i>
		James Madison Walker , <i>Managing Editor of Standards</i>
		Lauren Ramsdell , <i>Assistant Editor</i>
		Mary Bolton , <i>Editorial Assistant</i>
		Michshell Phillips , <i>Editorial Coordinator</i>
	PUBLISHING SERVICES	David Soltis , <i>Group Manager of Publishing Services</i>
		Jayne Jackson , <i>Publication Traffic Administrator</i>
	PUBLISHER	W. Stephen Comstock

Contents

- Introduction 1
- Purpose and Scope 3
- Related Work by Other Organizations 5
- Laws and Regulations 6
- Key Definitions 7
- Ventilation for Control of Airborne Hazards 9
- Components and Features of
 Laboratory Airflow Control Systems 10
- Laboratory Ventilation Design Levels 15
- Appendix—Criteria and Attributes for
 Laboratory Ventilation Design Levels 19
- References 33
- Bibliography 34

Introduction

The Laboratory Classification Subcommittee of ASHRAE Technical Committee (TC) 9.10, the Laboratory Health and Safety Committee of the American Industrial Hygiene Association (AIHA), and the Division of Chemical Health and Safety of the American Chemical Society (ACS) have partnered to provide this document to help facility professionals design and operate laboratories with the capability of supporting the management of exposures to airborne chemicals generated during laboratory scale activities. It is important to note that ventilation alone cannot handle all laboratory chemical hazards and that this document assumes other control measures, including minimization of chemical risks, good laboratory housekeeping, and appropriate emergency procedures, are also in place. There is a hierarchy of controls that is well established in the safety profession. Laboratory ventilation is a form of engineering controls, which is one layer in this hierarchy. (See the National Institute for Occupational Safety and Health [NIOSH] website www.cdc.gov/niosh/topics/hierarchy/default.html for more information on the hierarchy of controls [NIOSH 2016].)

For the purposes of this document, *laboratory scale* is defined as a workplace where hazardous chemicals are used on a nonproduction basis. The Occupational Safety and Health Administration (OSHA) laboratory standard 29 CFR 1910.1450(b) states:

Laboratory scale means work with substances in which the containers used for reactions, transfers, and other handling of substances are designed to be easily and safely manipulated by one person. “Laboratory scale” excludes those workplaces whose function is to produce commercial quantities of materials. (OSHA CFR n.d.)

While this definition does not place limits on the types or severity of chemical hazards used in laboratories, it does limit the quantity of materials potentially released into the laboratory environment to about 4 L (1 gal) or less per process. Mitigating the risk of exposure to laboratory scale generation of airborne chemical hazards means controlling airborne concentrations below levels known or suspected to cause harm to people, property, or the environment through a combination of general and local ventilation as well as the other measures referenced above.

The risk of exposure to unsafe concentrations of airborne chemicals in laboratories can range from negligible to extreme, depending on the activities conducted in the laboratories, the types of hazardous chemicals, the quantities of materials, the characteristics of generation, the duration of exposure, and the protection

afforded by the laboratory airflow and airborne contaminant control systems. For this reason, a risk assessment must be conducted based on the best available information about the chemical work to be conducted in the laboratory. The ability to mitigate the risk to people, property, and the environment depends on providing an adequate level of protection through proper design, operation, and utilization of the laboratory; the exposure control devices (ECDs), such as fume hoods; and the laboratory ventilation systems. Collectively, the ECDs, the exhaust systems, the air supply systems, and the elements of the laboratory that may affect airflow and control of airborne contaminants are referred to herein as the *laboratory airflow control system* (LACS). The purpose of the LACS is twofold: it must (1) help prevent overexposure to airborne chemical hazards generated during laboratory scale activities and (2) satisfy the temperature and humidity conditioning requirements of the occupants and the processes they conduct in the laboratory workspace.

The protective capability afforded by an LACS must be commensurate with the level of risk associated with the airborne chemical hazards that may be generated. Tables 2 and 3 provide physical design attributes and operating specifications for an LACS divided into five laboratory ventilation design levels (LVDLs) ranging from LVDL-0 to LVDL-4. The attributes and specifications for each LVDL are intended to provide increasing levels of protection and control of airborne chemical hazards to minimize the risk of overexposure. Specifically, an LACS with attributes and specifications associated with LVDL-0 offers the lowest level of protection for working with hazardous airborne chemicals, while an LACS designed and operated according to LVDL-4 recommendations offers the highest level and control of airborne hazards. It is important to note that this guide does not provide the tools needed to assess the risk associated with laboratory scale use of hazardous chemicals. The information contained herein can be used to evaluate the protective capability of an existing LACS or to help design and operate an LACS according to the anticipated level of risk or the degree of protection considered necessary to provide a safe and healthy laboratory environment. While higher LVDLs may increase the protective capability of the laboratory, they will also increase the costs of construction, result in greater energy consumption, increase operating costs, and increase the level of effort required to manage and maintain performance. These considerations must be carefully considered in the design and operation of laboratory facilities.

Laboratory safety is an inviolable constraint and must not be sacrificed for gains in productivity or operating efficiency. Protective measures must be available and appropriate to provide adequate protection and can include a combination of administrative controls, personal protection, and engineering controls.

Purpose and Scope

This effort is limited to issues related to design and operation of laboratories and their interactions with LACSs that provide conditioning and control of environmental air quality in laboratories. It does not seek to duplicate work under the purview of other ASHRAE committees or other organizations. Methods and tools to evaluate hazardous chemical procedures or assign a level of risk of airborne chemical hazards are also not a part of this effort. As such, adherence to the recommendations contained in Table 3 may not ensure adequate protection or adequately mitigate risk to all possible hazards without a comprehensive hazard evaluation by skilled practitioners. A risk assessment is strongly recommended to determine the appropriate LVDL, design attributes, and operating specifications.

This document provides background information to help classify, design, and operate LACSs according to the LVDL table included in the appendix (Table 3). The table describes criteria, design attributes, and operating specifications associated with each LVDL. The purpose of the LVDL classification system and Table A are to foster communication between stakeholders when evaluating the protective capability of an existing LACS or during discussions about design, construction, and operation of a new LACS intended to manage and control airborne chemical hazards.

The recommendations are based, to a large extent, on concepts outlined in the American Conference of Governmental Industrial Hygienists (ACGIH) publication *Industrial Ventilation, A Manual of Recommended Practice for Design* (ACGIH 2013), ANSI/AIHA/ASSE Z9.5, *Laboratory Ventilation* (AIHA 2012), and *ASHRAE Laboratory Design Guide* (ASHRAE 2015). Specifically, this document addresses considerations likely to be encountered during design, renovation, or ongoing management of laboratories, ECDs, and LACSs. By limiting the scope of this document to laboratory scale use of airborne hazards, other guidance for laboratory facility designers may be necessary to accommodate other hazards (i.e., biological, radiological, and physical hazards) not considered in this document. As such, protective measures for these other hazards that might be encountered in laboratories must be based on a comprehensive hazard and risk analysis.

This guide does not provide the means to assess the risk associated with airborne chemical hazards, the risk of exposure to other laboratory hazards, or the level of performance required of the systems. The five LVDLs outlined in this document may not align with the risk and safety levels described by other organizations. However, the classification system described herein can be used as a basis for design and operation of laboratories and evaluating the protective capabilities of existing laboratories. Health and safety specialists should be consulted

when investigating and determining the risks associated with hazardous processes and matching to the appropriate LVDL and the interactions of the LACS with other protective measures, such as emergency planning and personal protective equipment.

Related Work by Other Organizations

The American Chemical Society (ACS) Committee on Chemical Safety (CCS) documents best practices for safety in chemical activities and provides guidance, methods, and tools for assessing and controlling hazards in research laboratories at <http://acs.org/safety> (ACS n.d.).

For biological laboratories, important references are *Biosafety in Microbiological and Biomedical Laboratories (BMBL)* (CDC 2009) and *NIH Guidelines for Research Involving Recombinant or Synthetic Nucleic Acid Molecules (NIH Guidelines)* (NIH 2016).

Laws and Regulations

This guide serves as a resource to help control exposure to airborne chemical hazards used in laboratories. Elements of this guide are to be implemented in the absence of, or as a supplement to, respective laws and regulations, standards developed by authoritative bodies, and site-specific protocols. Where national or local laws require a higher (specific or additional) standard, they must be followed. Where national or local laws require less stringent standards, the facility guidelines and standards must be followed.

System design and operating requirements must comply with mandatory provisions of related codes and standards unless a waiver is granted. Nothing in this guide is intended to supersede requirements in codes or standards or the requirements of the authority having jurisdiction, nor is it intended to replace the need to consult with registered design professionals, code officials, and environmental health and safety specialists necessary to achieve safe workspaces for occupants and to protect the property or the environment from damage.

Key Definitions

The following definitions provide clarity and context for some of the terms used in this guide.

airborne chemical hazards: Chemicals suspended or mixed in air and which pose hazards that can be similarly controlled by ventilation strategies. These are primarily gases and vapors from volatile chemicals which present flammability, reactivity, toxicity hazards, or odor issues. Other types of airborne contaminants may include particulates, fumes, and aerosols. These are likely to require control strategies distinct from those of gases.

emergencies: Situations in which airborne chemical hazards are released in amounts or at rates beyond those anticipated during typical laboratory scale activities and processes. These situations require special or extraordinary action to return the laboratory space to acceptable conditions. The primary emergency response strategy involves evacuation of laboratory workers, a response by teams equipped with appropriate personal protection, and either an extended period of nonoccupancy or the provision of additional ventilation when available.

failure mode analysis: The process of identifying all failures that are possible in a system and evaluating the effects of those failures.

hazard: Anything in the workplace that has the potential to harm people, property, or the environment. Hazards can include objects in the workplace such as machinery or chemicals, biological materials, and radioisotopes. With respect to airborne hazards, the severity of the hazard is inherent in the properties of the material.

laboratories: Spaces in which the use of hazards meets OSHA's definition of laboratory scale: "work with substances in which the containers used for reactions, transfers, and other handling of substances are designed to be easily and safely manipulated by one person" (OSHA CFR n.d.). Laboratory scale excludes those workplaces whose function is to scale up or produce commercial quantities of potentially hazardous airborne materials.

laboratory ventilation design level (LVDL): Laboratory and ventilation design, components, and operating specifications that can be expected to control concentrations of airborne chemical hazards generated during laboratory scale procedures.

management of change: The ongoing oversight process that provides a mechanism to detect and respond to changes in laboratory processes and risk. This may require a reevaluation of the risk and a control banding assignment associated

with the work and modification of the systems to accommodate changes in functional or safety requirements.

risk: The probability of contact with an airborne concentration of hazards sufficient to cause harm to people (death, injury, or illness), property (degradation or corrosion) and the environment (pollution).

control banding: A hazard identification and risk assessment system that organizes information about hazards and processes into groups based on their relevance to the health and safety scenario of concern. Factors to consider in making this assignment in the context of laboratory ventilation include chemical hazard, quantity, and the potential for airborne emissions in the laboratories and building. It is important to note that some processes may fall outside a specific control banding system due to unusual hazards or application. Determination as to whether a specific area, device, or process is appropriate for control banding is the first step in making a control banding assignment.

ventilation effectiveness: The ability to reduce accumulation of unsafe concentrations through the combined mechanisms of dilution and contaminant removal throughout a laboratory room. Dilution in a well-mixed environment is a function of the air change rate, whereas ventilation effectiveness is a function of the airflow patterns resulting from how the air is supplied and exhausted from the space. Increasing the air change rate may not have a positive effect on ventilation effectiveness. Both the magnitude of the flow and the resulting airflow patterns within the laboratory must be considered to maximize ventilation effectiveness.

volatile chemicals: Chemicals that can be readily vaporized at relatively low temperatures (i.e., below 38°C [100°F]). The level of volatility correlates with the vapor pressure of the chemical and thus is chemical specific. For example, a material such as acetone has a high vapor pressure and a low boiling point, which equates to high volatility.

Ventilation for Control of Airborne Hazards

LACSS serve as the primary engineering control to reduce potential for harm to people, property, and the environment by controlling accumulation and migration of airborne chemical hazards generated in laboratories. The ventilation control techniques include containment, capture, dilution, and removal of airborne chemical hazards from the laboratory. LACSS include various types of ECDs such as fume hoods, snorkel extraction arms, biological safety cabinets, and glove boxes for local source capture. The LACS also includes the physical layout or topography of the laboratory that affects airflow patterns within the room, the air supply and exhaust systems, and the safe discharge of airborne contaminants from the building. The degree of protection afforded by the LACS depends on the coordinated design, operation, and use of all these elements.

The laboratory and the LACS must be appropriate for the chemical hazards and capable of providing adequate control and protection when properly designed, operating, and used by trained personnel. The level of risk and the demand for ventilation can vary between laboratories and within any laboratory over time depending on the occupants, the types of hazards, and the processes conducted. For this reason, management of change procedures are particularly important in a laboratory setting. A successful management of change program involves a variety of stakeholders, but the design basis of the laboratory ventilation system should include consideration of how to support changes in laboratory practices over time. Laboratory personnel must be trained to use proper work practices, understand the limitations of the LACS, and recognize when hazardous processes may exceed the capabilities of the LACS.

As part of this program, the design, construction, and operation of the LACS is based on potential applications and must be capable of providing adequate protection over a range of anticipated operating modes with the flexibility to accommodate reasonable changes in the demand for ventilation. Many different protection techniques and technologies are available to address this need and can be applied to meet the level of control and protection required. However, using the highest level of control for all laboratories to accommodate all possible current and future chemical emission scenarios is impractical and costly. Incorporating features that can be appropriate for all applications results in an LACS that can be overly complex, wasteful, and extraordinarily difficult to manage and maintain. As such, the level of control must be defined.

Components and Features of Laboratory Airflow Control Systems

The design, construction, operation, and use of LACSS affect the ability to control airborne chemicals, meet safety requirements, and satisfy the demand for ventilation. LACSS can range from simple, constant-volume (CV), independent systems to complex, variable-air-volume (VAV), manifolded systems capable of modulating airflow for multiple spaces over a range of operating modes. Figure 1 and Table 1 depict a complex, modern, VAV exhaust and air supply system capable of modulating flow in response to changes in the demand for ventilation.

Figure 1 is provided to show and describe the primary components of an LACS for reference during discussions with stakeholders who may not be familiar with the various components, attributes, and specifications described in the appendix.

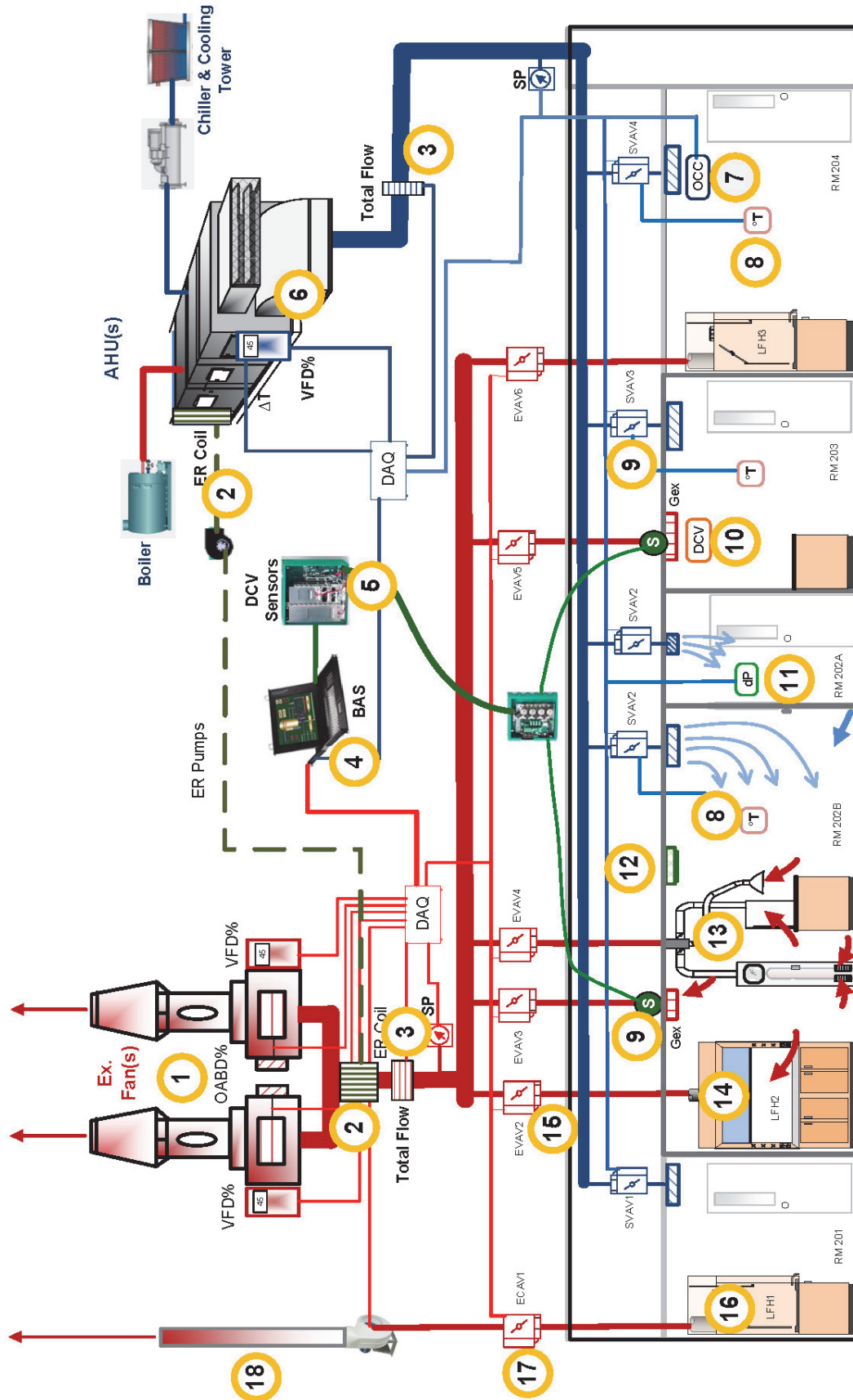

Figure 1 Simplified diagram of laboratories and LACS showing critical components and attributes.

Table 1 Typical Components of a Modern LACS

No.	Component/Feature	Description
1	Redundant N+1, exhaust fans with variable-frequency drives (VFDs) and outdoor-air bypass dampers (OABDs)	Dual exhaust fans (N+1) and stacks with continuous power backup. Installation of redundant fans enables better system dependability. The combination of the VFD OABDs optimizes the ability to reduce flow but maintain sufficient plume discharge when necessary. Flow control can be optimized by tuning the sequence of operations.
2	Energy recovery system	Various types of energy recovery systems can be used depending on the hazards in the exhaust. The type can affect efficiency and the potential for recirculation of exhaust. Options include runaround loops (least efficient, but safest), heat pipes (more efficient), and rotary heat exchangers (heat wheels) (most efficient, potentially least safe).
3	Flow monitors and system sensors	Exhaust and air supply systems often use flow and static pressure sensors. The measurement of total flow in addition to system static pressure improves system sensitivity flow tracking and enables reset of static pressure during periods of reduced demand. The ability to achieve better sensitivity and reduce static pressure can enable significant additional savings.
4	Building automation system (BAS)	The BAS can monitor operation, detect operational problems, and trend operation over time to provide useful operating metrics.
5	Contaminant-sensing demand-controlled ventilation (DCV)	A network of sensors can be installed to sample air quality and modulate or increase flow when chemicals are detected, enabling minimum airflow when contaminants are not detected in the environment. This improves the ability to increase flow for additional dilution when necessary rather than increasing flow to operate continuously for possible spill scenarios.
6	Air-handling unit (AHU) supplying 100% outdoor air to laboratories	AHUs can provide 100% outdoor air or be equipped to recirculate some portion of air supplied to the building. Recirculation is prohibited for laboratories that handle airborne hazards.
7	Occupancy sensors	Occupancy sensors detect the presence of people in the laboratory and enable flow to be reduced or set back when laboratories are vacant. Flow reduction lowers the air change rates, potentially enabling accumulation of concentrations and exposure upon laboratory reentry prior to purging.
8	Temperature sensors	Temperature sensors (i.e., thermostats) detect room temperature and translate signals to air supply discharge temperature control or another source for maintaining room temperature specifications.

Table 1 Typical Components of a Modern LACS *(continued)*

No.	Component/Feature	Description
9	Air supply controls and diffusers	The volume and distribution of room air supply can be critical to controlling room temperature and dilution and assisting with contaminant sweep and removal from the space. Improper location and type of supply diffusers can cause short-circuiting of air that reduces efficiency or can cause high-velocity cross-drafts that can interfere with ECD capture and containment.
10	DCV that detects airborne contaminants	Chemicals and/or other air contaminants can be accidentally released in the laboratory. When they are detected by sensors, the ventilation rate can be increased to promote faster dilution and removal. The detection of contaminants can be reported through the building information systems to alert occupants or responsible stakeholders such as environmental health and safety (EH&S) personnel.
11	Anteroom with critical room pressure monitoring and controls	Laboratories with a need for isolation to help prevent migration or escape of airborne hazards to nonlaboratory spaces can be equipped with anterooms or vestibules that serve as additional barriers to isolate the space and with room pressure monitors to indicate the airflow direction and differential pressure.
12	Airborne contaminant filtration system	Chemicals and/or other air contaminants can be accidentally released in the laboratory. Filter units can be installed with different types of media to scavenge airborne contaminants and assist with air movement and the effectiveness of the room ventilation systems. Some filter units are equipped with contaminant detectors and/or sensors to detect and alert users and responsible stakeholders such as EH&S personnel.
13	Exposure control devices (ECDs) (local exhaust ventilation)	ECDs (local exhaust ventilation) such as ventilated enclosures, snorkel exhaust arms, and hazardous gas cabinets can be installed to assist with source capture and reduce risk in the laboratory and need or reliance on room dilution ventilation as the primary means of protection. The ECDs must be appropriate for the airborne hazard and activity.
14	ECDs (VAV fume hoods)	VAV fume hoods provide a high level of protection and modulate flow in response to changes in the use of the fume hood. A VAV fume hood reduces flow depending on sash opening area, occupancy, or other conditions. The minimum flow must be sufficient to maintain containment, dilution, and removal of contaminants generated within the hood under that operating mode.

Table 1 Typical Components of a Modern LACS *(continued)*

No.	Component/Feature	Description
15	VAV exhaust flow controller	VAV terminals or valves comprise sensors, actuators, and flow dampers to modulate exhaust flow to satisfy the flow requirements of the VAV fume hood or other exhaust devices in the laboratory.
16	ECDs (CV fume hood)	CV fume hoods are designed for a constant volume of exhaust flow from the fume hood. CV operation is sometimes necessary for containment or where high rates of contaminant generation could cause problems at reduced flow and lower duct transport velocities.
17	CV exhaust flow controller	CV terminals or airflow control valves are used to maintain a constant flow of air through the exhaust device regardless of operating mode.
18	Exhaust stack	The design height and ejection velocity can be critical to ensuring adequate discharge of contaminated exhaust air from the laboratory and ECDs. The height, velocity, and stack design can affect the dispersion of the contaminated plume and the potential for exposure of people working on the roof and nearby. A common problem resulting from improper discharge of airborne hazards is reentrainment into the air supply systems.

Laboratory Ventilation Design Levels

Estimating risks and the consequent demand for ventilation can help establish appropriate specifications for design and operation of laboratories, ECDs, and the overall systems. Similarly, an evaluation of the existing LACS can help determine the existing level of protection and the inherent potential for protection. Knowing the level of protection afforded by the LACS can help determine suitability for applications involving hazardous airborne materials or reveal the need to modify the design or operation based on the risk and required protection. The protective capability of an LACS is based on a combination of physical design attributes and operating specifications such as the air change rates and volume of flow.

This guide categorizes the design and operation of LACSs in five laboratory ventilation design levels (LVDLs). Each level is associated with a different level of protective capability by virtue of design features (physical attributes) and operating characteristics. As shown in Figure 2, an LVDL-0 represents a laboratory that offers negligible control of airborne hazards and is appropriate for the lowest risk activities, whereas an LVDL-4 represents an LACS with features, attributes, and operating characteristics that can offer the highest level of protection. The level of protection afforded by the LACS is not subject to a single design feature or operating specification such as air changes per hour (ACH). Rather, the LVDL and level of protective capability are based on a combination of the components, features, and specifications that make up the LACS. Higher LVDLs can be associated with higher costs for construction, greater energy consumption, increased complexity, higher operating costs, and greater levels of effort to manage and maintain them.

It is also important for facility owners to recognize that selection of an LVDL for laboratories during design will impact the type of activities appropriate to be conducted in the laboratories after they are built. Before hazardous work occurs in these spaces, a specific review must be performed to determine whether the work is consistent with the assumptions made during the project planning, design, and construction processes. Resources for conducting laboratory hazard and risk assessments are likely to be available in institution-specific information such as institutional design standards, a Laboratory Ventilation Management Plan (as required by AIHA/ASSE Z9.5 [AIHA 2012]), or other systems and guidance documents developed by environmental health and safety (EH&S) staff. These resources should be consulted early in the design development phase or when evaluating the suitability of a laboratory for conducting work with airborne hazards.

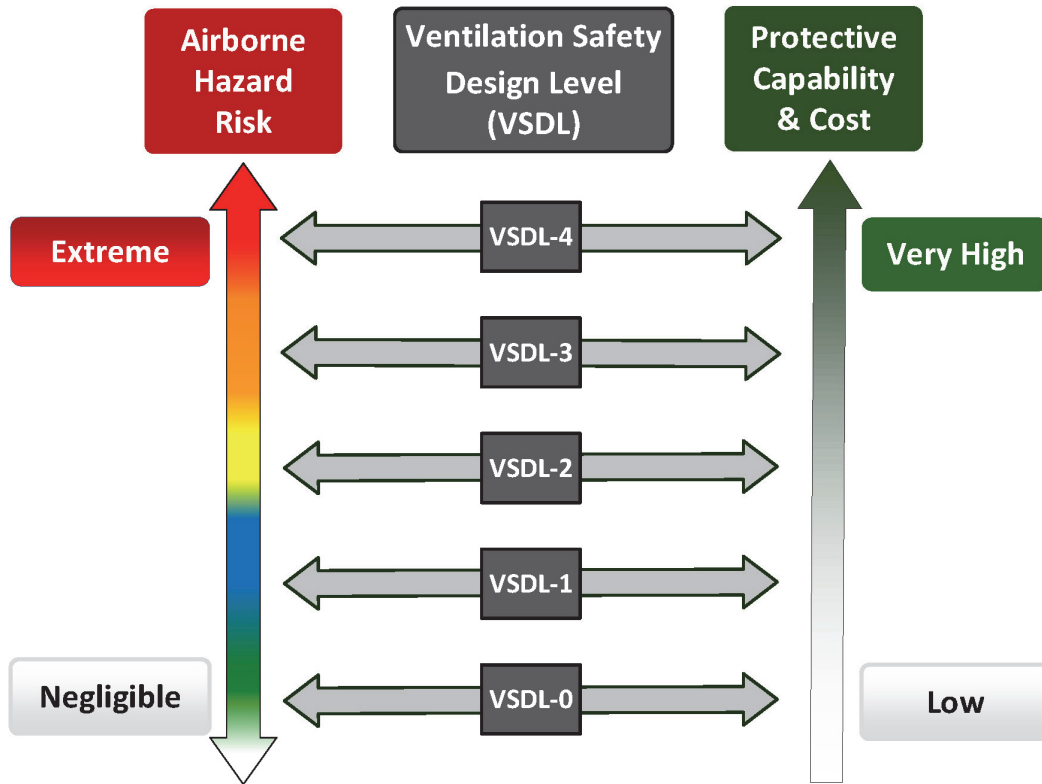

Figure 2 Risks associated with airborne hazards and the levels of protection associated with the range of LVDLs.

Table 2 describes the general characteristics and typical application of laboratories by LVDL. The table of LVDL requirements for design and operation in the appendix provides recommendations for design features, attributes, and specifications for the different LVDLs.

Table 2 General Characteristics and Laboratory Types Associated with LVDLs

General Characteristics						
LVDL	Quantities of Hazardous Materials	Potential for Airborne Generation	Hazard Severity	Control Strategy	Construction and Operating Costs	Types of Laboratories or Applications
LVDL-0	Negligible	Negligible	Negligible—no GHS* danger chemicals	Dilution ventilation only	Low	<ul style="list-style-type: none"> • Computer and instrumentation laboratories • Secondary school teaching laboratories • Temperature-controlled rooms (warm rooms and cold rooms)
LVDL-1	Small	Negligible	Low (consumer chemicals)	Dilution and local exhaust ventilation points	Moderate	<ul style="list-style-type: none"> • Secondary school teaching laboratories • Shop areas with point sources of hazardous chemicals • Quality control laboratories • Biology laboratories with no volatile hazards beyond disinfectants
LVDL-2	Moderate	Low	Low to moderate (GHS codes that might apply to any chemicals used or produced by the process: H333, H334 and H335, and H226 and H227)	Dilution and removal, local exhaust ventilation, fume hoods	High	<ul style="list-style-type: none"> • Upper-level undergraduate research laboratories • Biochemistry laboratories focused on aqueous solutions • Academic teaching laboratories

* GHS = Globally Harmonized System of Classification and Labeling of Chemicals (OSHA GHS n.d.)

Table 2 General Characteristics and Laboratory Types Associated with LVDLs (continued)

General Characteristics						
LVDL	Quantities of Hazardous Materials	Potential for Airborne Generation	Hazard Severity	Control Strategy	Construction and Operating Costs	Types of Laboratories or Applications
LVDL-3	Large	High	High (GHS codes that might apply to any chemicals used or produced by the process: H331, H332, H333, H334 and H335, H336 and H226, H227, H229, H242, H261)	Dilution and removal, local exhaust ventilation, fume hoods, special ECDS (isolators)	Very high	<ul style="list-style-type: none"> Inorganic/organic synthesis laboratories Typical research laboratories
LVDL-4	Very large	Very high	Extreme (GHS codes that might apply to any chemicals used or produced by the process: in addition to the hazard codes from LVDL-3, these might also apply: H330, H331 and H204, H205, H220, H224, H240, H250, H260)	Dilution and removal, local exhaust ventilation, fume hoods, special ECDS	Extreme	<ul style="list-style-type: none"> Chemical development laboratories Polymer synthesis laboratories Organic/inorganic chemical synthesis laboratories Special high-hazard research laboratories

* GHS = Globally Harmonized System of Classification and Labeling of Chemicals (OSHA GHS n.d.)

Appendix— Criteria and Attributes for Laboratory Ventilation Design Levels

Table 3 provides recommended criteria, operating specifications, and design attributes for each LVDL. The table is divided into sections based on the general area of application and recommended criteria for design and operation. Each section is further subdivided into individual criteria and a description of each criterion as it applies to each LVDL. As stated previously, LVDL-0 to LVDL-4 represent increasing levels of protective capability, complexity, costs, etc. The information contained in Table 3 can be used to promote communication between stakeholders and offer a level of design and operation commensurate with the actual or perceived level of risk applicable to the laboratory activities.

For existing laboratories, the design and operation of the LACS can be matched with the criteria and description to assign an LVDL. During design of new laboratories or when modifying LACSs, Table 3 can be used to determine the design level appropriate for the anticipated risk. Where there is great uncertainty as to the types of activities that might be conducted and where the range of risks may vary widely, it would be prudent to design and operate the LACS according to LVDL-4 recommendations. However, budgetary constraints and other issues may warrant designing to a lower LVDL. In these cases, it is necessary to ensure all stakeholders are aware of the limitations and to ensure the space provides adequate protection in combination with other protective measures. Finally, an LACS can be designed for higher LVDLs but operate according to lower LVDLs when appropriate to conserve energy and reduce operating costs. Each laboratory and LACS should be appropriately and conveniently labeled with both the LVDL capability and the current operating level at the laboratory, and/or this information should be available in a central repository for building design information.

Table 3 LVDL Requirements for Design and Operation

ID	Criterion Description	LVDL-0 Requirement	LVDL-1 Requirement	LVDL-2 Requirement	LVDL-3 Requirement	LVDL-4 Requirement
Air Recirculation Considerations						
1	Air recirculation within the same space is permissible (by use of supplemental space recirculation units)	Yes	Yes, where permitted by ANSI/ASHRAE Standard 62.1 (for Class I, II or III air) (ASHRAE 2016).	Same as LVDL-1	Same as LVDL-1	No
			Confirm system compatibility (e.g., materials compatibility, potential equipment corrosion, equipment accessibility, reactivity with cooling coil condensation, etc.)			

Table 3 LVDL Requirements for Design and Operation (continued)

ID	Criterion Description	LVDL-0 Requirement	LVDL-1 Requirement	LVDL-2 Requirement	LVDL-3 Requirement	LVDL-4 Requirement
Air Recirculation Considerations (continued)						
2	Enthalpy wheels permitted	Yes, where permitted by Standard 62.1.1.	Same as LVDL-0	Same as LVDL-0	Yes, if determined safe for present and future applications by hazard analysis (including failure scenarios), materials compatibility and code-compliance.	No
		Limit carryover per Standard 62.1 for Class I air.			Limit carryover per Standard 62.1 for the applicable air classification.	
3	Air recirculation at a central air-handling system is permissible (where the system serves more than one space)	Yes, where permitted by Standard 62.1 (for Class I or II air only). Requires review and approval by an EH&S professional.	No	No	No	No

Table 3 LVDL Requirements for Design and Operation (continued)

ID	Criterion Description	LVDL-0 Requirement	LVDL-1 Requirement	LVDL-2 Requirement	LVDL-3 Requirement	LVDL-4 Requirement
Supply and Exhaust Airflow Requirements						
4	Occupied minimum exhaust ventilation rate (See the text for the application of minimum ventilation rates, which should not be determined without the supporting risk analysis under any condition.)	Standard 62.1	Standard 62.1	4–6 air changes based on sufficient information for hazard review by an EH&S professional and completion of review. General ventilation rate may be lower if validation of effectiveness of ventilation suggests sufficient dilution and contaminant removal.	If all emission sources of concern are contained by use of local exhaust ventilation, and if inadequate air distribution or mixing from the general ventilation system is not a concern: <ul style="list-style-type: none"> Typically 6 ach*, otherwise: Increase air changes per hour (8 or more*) or investigate and improve ventilation effectiveness. 	If all emission sources of concern are contained by use of local exhaust ventilation, and if inadequate air distribution or mixing from the general ventilation system is not a concern: <ul style="list-style-type: none"> Typically 8 ach*, otherwise: Increase ACH (10 or more*) or investigate and improve ventilation effectiveness.
					General ventilation rate may be lower if validation of effectiveness of ventilation suggests sufficient dilution and contaminant removal.	General ventilation rate may be lower if validation of effectiveness of ventilation suggests sufficient dilution and contaminant removal.
					* Scale minimum air change rates upward based on project-specific indoor air quality sensing can be used to support the results of this analysis.	* Scale minimum air change rates upward based on project-specific analysis. Technologies such as indoor air quality sensing can be used to support the results of this analysis.

Table 3 LVDL Requirements for Design and Operation (continued)

ID	Criterion Description	LVDL-0 Requirement	LVDL-1 Requirement	LVDL-2 Requirement	LVDL-3 Requirement	LVDL-4 Requirement
Supply and Exhaust Airflow Requirements (continued)						
5	Unoccupied minimum exhaust ventilation rate	Standard 62.1 (for unoccupied conditions)	Standard 62.1 (for unoccupied conditions)	Standard 62.1 (for unoccupied conditions)	Typically, 4 ach*. General ventilation rate may be lower if validation of effectiveness of ventilation suggests sufficient dilution and contaminant removal.	Same as LVDL-3
<p><i>*Scale minimum air change rate upward or downward based on project-specific analysis. Technologies such as indoor air quality sensing can be used to support the results of this analysis.</i></p>						
6	Evaluation/confirmation of room ventilation effectiveness	Using standard design practice, evaluate supply, return, and exhaust device locations and types so as to provide adequate mixing of supply air with room air and prevent stratification.	Same as LVDL-0	Same as LVDL-0	Same as LVDL-0	LVDL-0 requirements plus verify room ventilation effectiveness via dispersion modeling or physical measurements.

Table 3 LVDL Requirements for Design and Operation (continued)

ID	Criterion Description	LVDL-0 Requirement	LVDL-1 Requirement	LVDL-2 Requirement	LVDL-3 Requirement	LVDL-4 Requirement
Supply and Exhaust Airflow Requirements (continued)						
7	Consider continuous indoor air quality monitoring	If specific volatile chemicals of concern are identified (for example, O ₂ levels in temperature control rooms)	No	No	When specific volatile contaminants of concern are identified	As specified by project requirements
8	Ventilation diversity factor	Should be considered	Should be considered	Should be considered	Should be considered	Should not be considered
8	Cooling diversity factor	Should be considered	Should be considered	Should be considered	Should be considered	Should not be considered
10	Heating diversity factor	Should be considered	Should be considered	Should be considered	Should be considered	Should not be considered
11	exhaust capture velocities	Not applicable	Canopy hood face velocities should be based on capture criteria	Same as LVDL-1	Consider project-specific analysis	Perform project-specific analysis
Design and Equipment						
12	Exhaust air filtration or treatment	Not applicable	No	No	No	Should be considered in specific situations

Table 3 LVDL Requirements for Design and Operation (continued)

ID	Criterion Description	LVDL-0 Requirement	LVDL-1 Requirement	LVDL-2 Requirement	LVDL-3 Requirement	LVDL-4 Requirement
Design and Equipment (continued)						
13	Spark protection and explosion-proof exhaust fans	Not applicable	Should be considered for laboratory exhaust systems	Same as LVDL-1	Same as LVDL-1	Same as LVDL-1
14	Duct materials	Use standard design practice	Same as LVDL-0	Verify fume hood and/or laboratory exhaust duct materials are appropriate	Same as LVDL-2	Same as LVDL-2
15	Equipment redundancy	Not required	Not required	Not required	Yes.	Yes.
					Exhaust and supply air systems should have multiple components.	Exhaust and supply Air systems should have N+1 redundancy.
					N+1 is not required.	
16	Operable windows permitted	Yes	Yes	No	No	No
17	Manifolding permitted	Yes	Yes	Yes	Yes	Yes.
						Verify chemical compatibility.

Table 3 LVDL Requirements for Design and Operation (continued)

ID	Criterion Description	LVDL-0 Requirement	LVDL-1 Requirement	LVDL-2 Requirement	LVDL-3 Requirement	LVDL-4 Requirement
Design and Equipment (continued)						
18	Vestibule required	No	No	No	Should be considered for some applications, such as the following: <ul style="list-style-type: none"> • Laboratories with cascading pressures • Laboratories with tight temperature and/or relative humidity requirements • Laboratories with tight particulate-level requirements (e.g., laser laboratories) • Laboratories that need to be maintained at a high differential pressure with respect to neighboring spaces. 	Same as LVDL-3.
19	Emergency power	Nothing beyond life safety requirements	Nothing beyond life safety requirements	Nothing beyond life safety requirements	Life safety requirements plus: <ul style="list-style-type: none"> • Fume hood exhaust air should be considered • Minimum lighting levels on the laboratory bench should be considered 	LVDL-3 requirements plus: <ul style="list-style-type: none"> • General exhaust air should be considered • Supply air should be considered in order to prevent excessive negative pressurization

Table 3 LVDL Requirements for Design and Operation (continued)

ID	Criterion Description	LVDL-0 Requirement	LVDL-1 Requirement	LVDL-2 Requirement	LVDL-3 Requirement	LVDL-4 Requirement
Dispersion Modeling Requirements						
20	Dispersion modeling to assess building reentrainment	No	No	No	Yes	Yes
Controls Requirements						
21	VAV permitted	Yes	Yes	Yes. CV fume hood exhaust should be considered. For VAV fume hood exhaust, minimum duct velocities should be considered.	Same as LVDL-2	LVDL-3 requirements plus the supply and exhaust systems should be capable of operating in a CV mode during an event.
22	Differential pressure or air volume offset control	Not required	Control required during emergency mode of operation only (where applicable)	Control required during normal mode of operation. Differential pressure should be verified.	Same as LVDL-2	LVDL-2 requirements plus minimum differential pressure of 0.01 in. w.g. Differential pressure should not be significant enough to impact egress.

Table 3 LVDL Requirements for Design and Operation (continued)

ID	Criterion Description	LVDL-0 Requirement	LVDL-1 Requirement	LVDL-2 Requirement	LVDL-3 Requirement	LVDL-4 Requirement
Controls Requirements (continued)						
23	Ventilation parameter monitoring (e.g., exhaust airflow, differential pressure, air volume offset, etc.)	Alarm when any monitored laboratory conditions are outside their respective acceptable ranges.	Same as LVDL-0	LVDL-0 requirements plus: <ul style="list-style-type: none"> Provide local alarms for fume hoods Provide continuous monitoring of laboratory exhaust airflow 	LVDL-2 requirements plus consider monitoring laboratory differential pressure.	LVDL-3 requirements plus: <ul style="list-style-type: none"> Provide continuous monitoring of laboratory differential pressure Consider local audible and/or visual alarms for laboratory exhaust airflow and/or differential pressure
24	Use of trend data	Not required	Not required	Required	Required	Required
25	Emergency purge mode	Not required	Not required	Should be considered	Should be considered	Should be considered

Table 3 LVDL Requirements for Design and Operation (*continued*)

ID	Criterion Description	LVDL-0 Requirement	LVDL-1 Requirement	LVDL-2 Requirement	LVDL-3 Requirement	LVDL-4 Requirement
General Laboratory Management						
26	Management of change	Potential for increase in chemical use to LVDL-1 is unlikely but possible with significant changes to the ventilation system design.	Potential for increase in chemical use to LVDL-2 is unlikely but possible with significant changes to the ventilation system design.	Potential for increase in chemical use to LVDL-3 is unlikely but possible. Ventilation requirements should be increased to 6–8 ach should space use changes to LVDL-3 or LVDL-4 occur.	Potential for increase in chemical use to LVDL-4 is unlikely but possible with significant changes to the ventilation system design. Ventilation requirements should be increased to 8–10 ach should space use changes to LVDL-4 occur, which would require a safety analysis.	Changes to laboratory require a safety analysis.

Table 3 LVDL Requirements for Design and Operation (*continued*)

ID	Criterion Description	LVDL-0 Requirement	LVDL-1 Requirement	LVDL-2 Requirement	LVDL-3 Requirement	LVDL-4 Requirement
General Laboratory Management (continued)						
27	Failure mode analysis	Not required	Not required	Not required	Perform failure mode analysis for the following conditions, at a minimum: <ul style="list-style-type: none"> • Exhaust system failure • Loss of normal power and operations during use of standby power • Loss of laboratory supply or makeup air • Loss of laboratory differential pressure 	Same as LVDL-3
28	Building/room tightness	Same as general office construction	Same as general office construction	Room construction should be sufficiently tight in order to meet the differential pressure requirements (see criterion 20). Wall penetrations should be sealed, and limitations to door undercuts should be considered.	Same as LVDL-2	LVDL-2 requirements plus: <ul style="list-style-type: none"> • Consider performing a visual integrity test around the room perimeter (e.g., smoke or soap bubble tests) • Consider making the room leakage adjustable (e.g., using door sweeps) • If room decontamination needs to be performed, additional tightness may be required.

Table 3 LVDL Requirements for Design and Operation (*continued*)

ID	Criterion Description	LVDL-0 Requirement	LVDL-1 Requirement	LVDL-2 Requirement	LVDL-3 Requirement	LVDL-4 Requirement
General Laboratory Management (continued)						
29	Signage within room	Provide required signage applicable to LVDL-0 laboratories	Provide required signage applicable to LVDL-1 laboratories	Provide required signage applicable to LVDL-2 laboratories	Provide required signage applicable to LVDL-3 laboratories	Provide required signage applicable to LVDL-4 laboratories
30	Testing, adjusting, and balancing	Required	Required	Required	Required	Required
31	Documentation	Provide equipment operating manuals and a commissioning report (if applicable)	Same as LVDL-0	LVDL-0 requirements plus fume hood (and/or other ventilation equipment) containment test reports.	Same as LVDL-2	Same as LVDL-2

Table 3 LVDL Requirements for Design and Operation (continued)

ID	Criterion Description	LVDL-0 Requirement	LVDL-1 Requirement	LVDL-2 Requirement	LVDL-3 Requirement	LVDL-4 Requirement
General Laboratory Management (continued)						
32	Commissioning or performance verification	Validate space temperature controls systems	Same as LVDL-0	LVDL-0 requirements plus: <ul style="list-style-type: none"> • Validate all makeup air, exhaust, and ventilation systems • Consider specific systems that warrant additional validation, including failure mode testing, to coincide with the anticipated associated risks 	Same as LVDL-2	LVDL-2 requirements plus consider facility pressure mapping

References

- ACGIH. 2013. *Industrial ventilation: A manual of recommended practice for design*, 28th ed. Cincinnati, Ohio: American Conference of Governmental Industrial Hygienists, 2010.
- ACS. n.d. Chemical & laboratory safety. Washington, DC: American Chemical Society. <http://acs.org/safety>.
- AIHA. 2012. ANSI/AIHA/ASSE Z9.5-2012, *Laboratory ventilation*. Falls Church, VA: American Industrial Hygiene Association.
- ASHRAE. 2016. ANSI/ASHRAE Standard 62.1, *Ventilation for acceptable indoor air quality*. Atlanta: ASHRAE.
- ASHRAE. 2015. *ASHRAE laboratory design guide: Planning and operation of laboratory HVAC systems*, 2nd ed. Atlanta: ASHRAE.
- CDC. 2009. *Biosafety in microbiological and biomedical laboratories (BMBL)*, 5th ed. DHHS Publication No. (CDC) 21-1112. Atlanta: Centers for Disease Control and Prevention, U.S. Department of Health and Human Services. www.cdc.gov/biosafety/publications/bmb15.
- NIH. 2016. *NIH guidelines for research involving recombinant or synthetic nucleic acid molecules (NIH guidelines)*. Bethesda, MD: National Institutes of Health, Department of Health and Human Services. https://osp.od.nih.gov/wp-content/uploads/2013/06/NIH_Guidelines.pdf.
- NIOSH. 2016. Hierarchy of controls. Atlanta: National Institute for Occupational Safety and Health, Centers for Disease Control and Prevention. <https://www.cdc.gov/niosh/topics/hierarchy/default.html>.
- OSHA CFR. n.d. *Code of Federal Regulations*. 29 CFR 1910.1450, Occupational exposure to hazardous chemicals in laboratories. Washington, DC: Occupational Safety and Health Administration. Accessed April 2018. https://www.osha.gov/pls/oshaweb/owadisp.show_document?p_table=STANDARDS&p_id=10106.
- OSHA GHS. n.d. The Globally Harmonized System for Hazard Communication. Foundation of Workplace Chemical Safety Programs. Accessed April 2018. <https://www.osha.gov/dsg/hazcom/global.html>.

Bibliography

- ACS. 2013. *Identifying and evaluating hazards in research laboratories*. Washington, DC: American Chemical Society.
- Diberardinis, L.J. 2013. *Guidelines for laboratory design*, 4th ed. New York: John Wiley and Sons.
- Dougherty, T.M. 1999. Chapter 6, Risk assessment techniques. In *Handbook of occupational safety and health*, 2nd ed. Ed. L. DiBerardinis. New York: John Wiley and Sons.
- Heinsohn, R.J. 1991. *Industrial ventilation: Engineering principles*. New York: John Wiley and Sons.
- Smith, T.C., and S.M. Crooks. 1996. implementing a laboratory ventilation management program. *Journal of Chemical Health and Safety* 3(2):12–16.